



KNIGHT TABLE SPORT

ACADEMY 19 & ELITE 22 INDOOR

Please read these instructions carefully before you start to assemble or use this table tennis table. They contain important information relating to safety, assembly and maintenance.

We recommend you keep these instructions for future reference in case you need to order spare parts or carry out any maintenance.

Assembly should be carried out by two adults throughout each stage.

Preparation for use

1. Open the carton and check to ensure all accessories and fittings are complete.
2. Install 'T' rolling leg according to figure 1 below.
3. Tighten all screws and turn table up the right way ready for use.

Assembly Instructions

Carefully undo the box. Unlock and unfold the pre-assembled legs on the underside of one of the tops (see diagram on the next page that shows the two locking points). Slide the 'T' shaped wheel bars onto the legs ensuring the coloured tape is in line on both the 'T' bar and also the leg then secure with bolts as shown below. Move the completed top away from the other taking extreme care to ensure it doesn't scrape or drag on the other top (to avoid damage or scratches). Turn the finished table top onto its wheels. Repeat these steps for the other half. You can view a video on YouTube that shows the assembly process. Search 'how to build a Knight Academy 19 or Knight Elite 22 indoor table tennis table'.

Figure 1

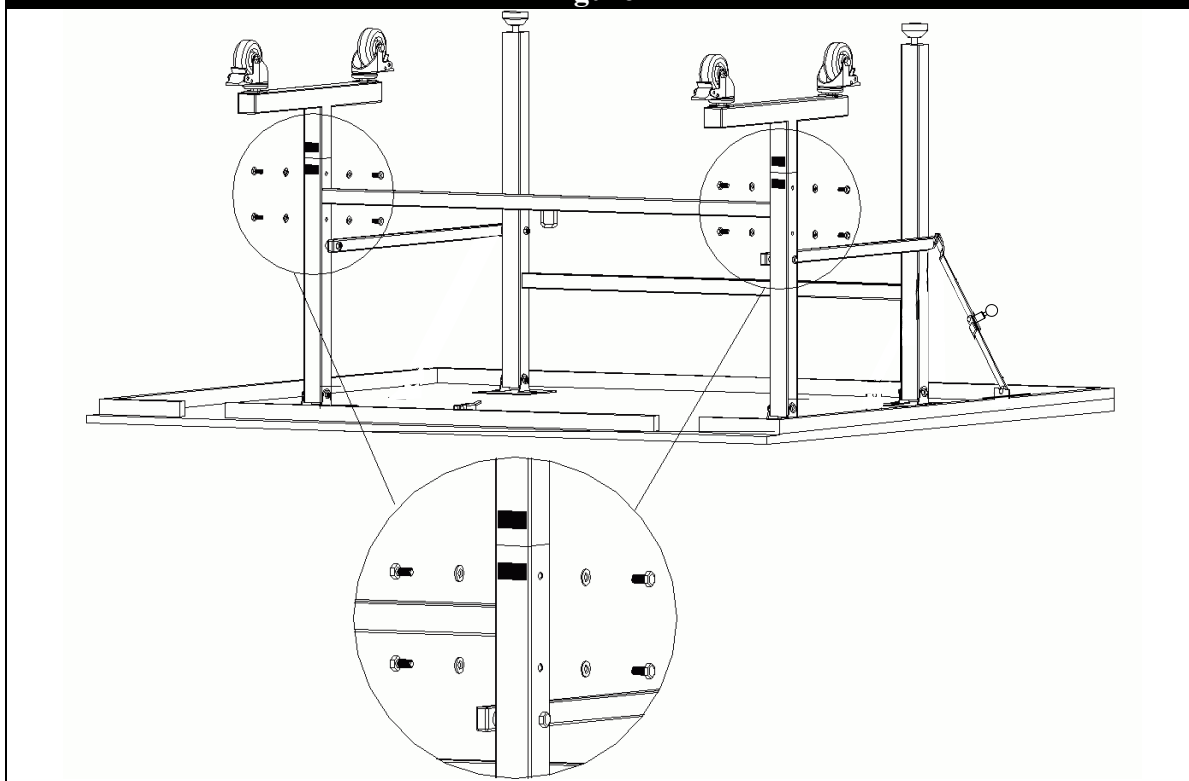

Care and Maintenance

1. Move the two halves slightly away from each other before opening and closing; this will avoid any contact between the tops.
2. Do not use or store the table outside. Both direct sunlight and damp conditions can cause the table to warp.
3. Avoid excessive contact of the bat against the table top.
4. Do not place hot goods on the table top.
5. Do not sit or place heavy goods on the table.
6. Do not use the table for any exercise other than table tennis.
7. Do not move the table around quickly on bumpy, rugged ground.
8. Keep the table in a dry, well insulated area.
9. **CLEANING YOUR TABLE:** It is very important to ensure the table does not get wet. Even a wet cloth can damage the surface! To get dust off the table you can use a very slightly moistened cloth. Ideally we recommend using a specialist cleaning spray (which can be purchased from most table tennis equipment suppliers). Do not use any cleaning products that are not specially designed for indoor table tennis tables.

Operation Method

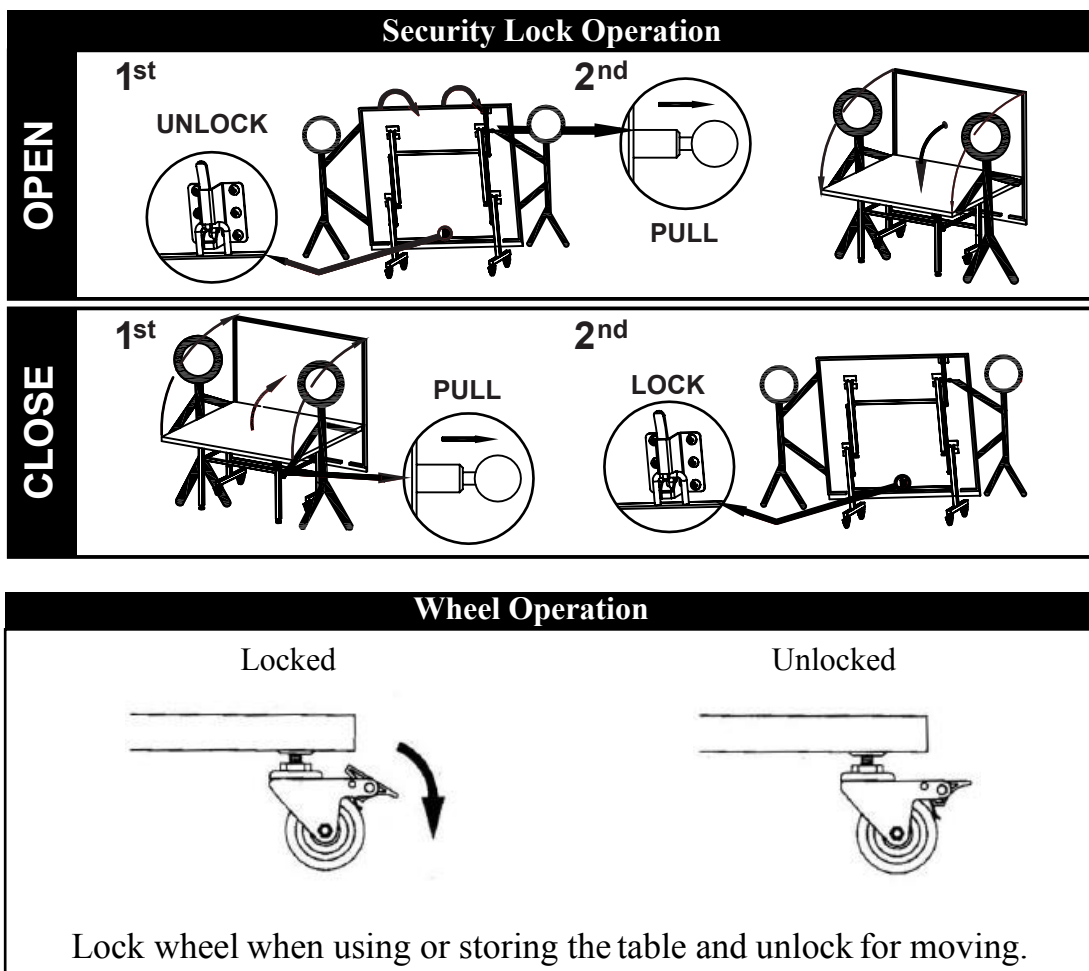

Height Adjusting Method

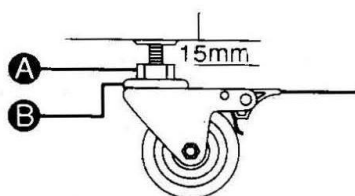
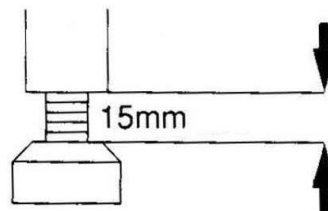

Figure 5

The wheel height can be adjusted by a maximum of 15mm.

To adjust the table height at the wheel screw part A (as seen in figure 5) anti-clockwise to raise the table or Part B clockwise to lower it.



The foot height can also be adjusted by a maximum of 15mm.

To adjust table height at the foot, screw foot anti-clockwise to raise the table or clockwise to lower it.

Notes on Safety

- The table tennis table should be used only for its intended purpose. All other uses may be dangerous. The manufacturer cannot be held liable for damage or injury caused by improper use of the table.
- Instruct others (particularly children) of any potential source of danger, especially when folding and unfolding the table (which should always be done by adults).
- The table tennis table should only be moved in the transport position as otherwise there may be a danger of damage or injury.
- Depending on frequency of use, check all screws, bolts etc. regularly to ensure that they are in good condition.
- Caution: while assembling the product, keep out of the reach of children (choking hazard – contains small parts).
- Do not use the table tennis table until it has been fully and correctly assembled and checked.
- Do not use corrosive or abrasive materials to clean the equipment. In most cases, a very slightly moistened cloth is sufficient. There are specialist cleaning sprays available from most good retailers.
- For any further information please contact your KNIGHT dealer.

www.knighttablesport.co.uk

e-mail:sales@knighttablesport.co.uk